

VVM3 - Vodomer sa mokrim mehanizmom - 1/2 " (bez pripreme za daljinsko očitavanje) - 5.112.500

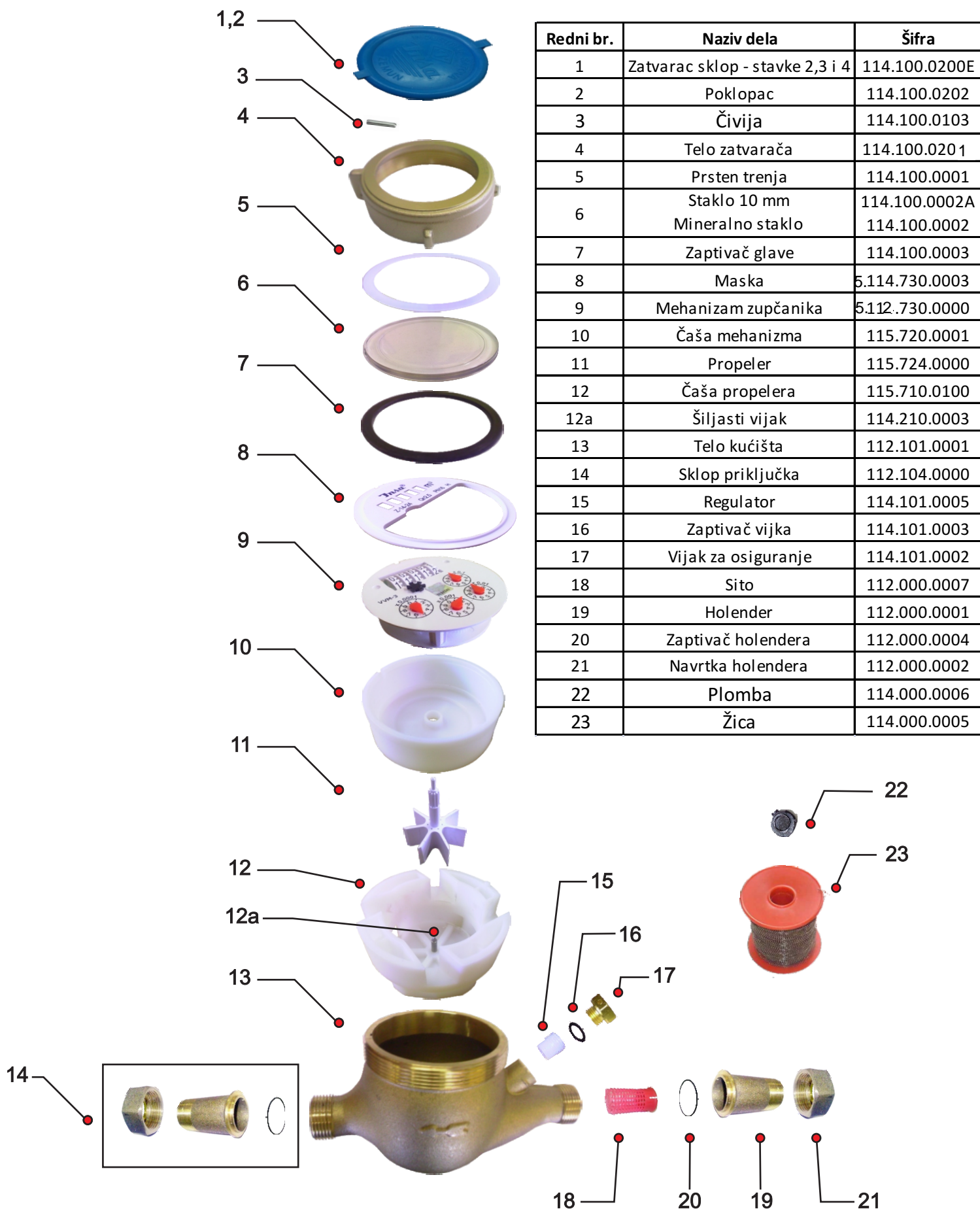

Redni br.	Naziv dela	Šifra
1	Zatvarac sklop - stavke 2,3 i 4	114.100.0200E
2	Poklopac	114.100.0202
3	Čivija	114.100.0103
4	Telo zatvarača	114.100.0201
5	Prsten trenja	114.100.0001
6	Staklo 10 mm Mineralno staklo	114.100.0002A 114.100.0002
7	Zaptivač glave	114.100.0003
8	Maska	5.114.730.0003
9	Mehanizam zupčanika	5.112.730.0000
10	Čaša mehanizma	115.720.0001
11	Propeler	115.724.0000
12	Čaša propelera	115.710.0100
12a	Šiljasti vijak	114.210.0003
13	Telo kućišta	112.101.0001
14	Sklop priključka	112.104.0000
15	Regulator	114.101.0005
16	Zaptivač vijka	114.101.0003
17	Vijak za osiguranje	114.101.0002
18	Sito	112.000.0007
19	Holender	112.000.0001
20	Zaptivač holendera	112.000.0004
21	Navrtka holendera	112.000.0002
22	Plomba	114.000.0006
23	Žica	114.000.0005

VVM3 - Vodomer sa mokrim mehanizmom - 1/2 " (bez pripreme za daljinsko očitavanje) - 5.112.500

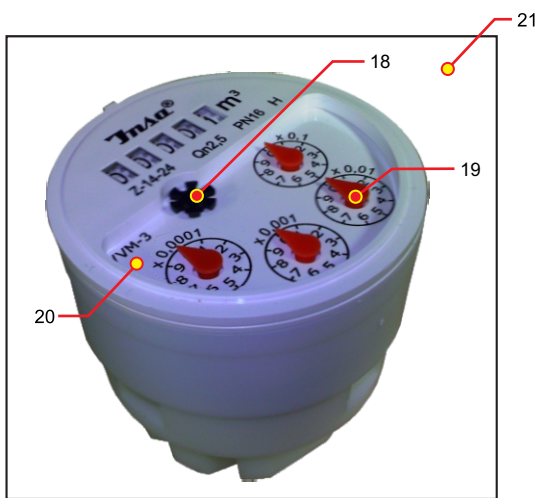
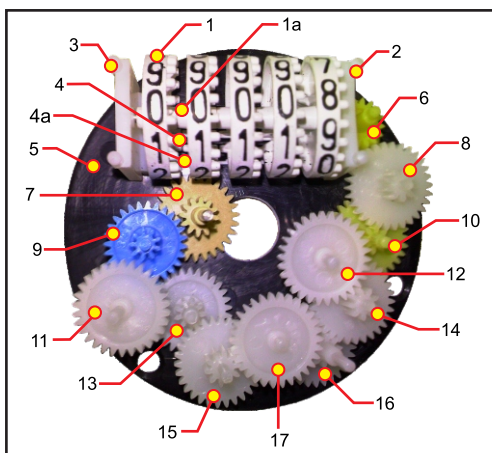

Redni br.	Naziv dela	Šifra
1	Doboš	114.230.01.00
1a	Osovina doboša	114.230.00.09
2	Nosač - levi	114.230.00.07
3	Nosač - desni	114.230.00.08
4	Osovina gonila	151.210.00.08
4a	Gonilo	114.230.00.11
5	Platina - donja	114.730.00.06
6	Zupčanik 390m	114.230.12.00
7	Zupčanik 393c	117.230.03.00
8	Zupčanik 391a	114.230.04.00
9	Zupčanik 391bz	115.730.04.00
10	Zupčanik 390c	114.230.11.00
11	Zupčanik 395a	114.230.10.00
12	Zupčanik 395a	114.230.10.00
13	Zupčanik 390a	115.730.11.00
14	Zupčanik 391a	114.230.04.00
15	Zupčanik 394a	114.230.07.00
16	Zupčanik 393a	114.230.09.00
17	Zupčanik 392a	114.230.08.00
18	Indikator	114.700.00.01
19	Kazaljka - šiljasta	114.230.00.02
20	Platina - gornja	5.114.730.02.01
21	Mehanizam vodomera	5.112.700.00.00

Poprečni presek mehanizma sa opisom delova:

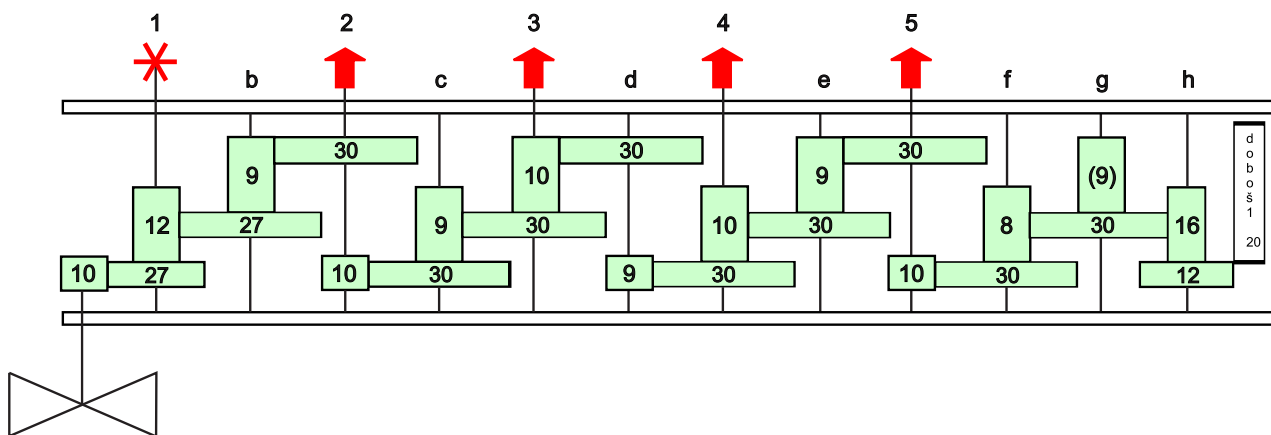

Osa	-	1	b	2 (0.1 lit)	c	3 (1 lit)	d	4 (10 lit)	e	5 (100 lit)	f	g	h	-
Oznaka	gon	393c	391bz	395a	390a	394a	392a	393a	391a	395a	390c	391a	390m	1.dob
z	10	27	12	27	9	30	10	30	9	30	10	30	8	30
m [mm]	0.5	0.45	0.45	0.45	0.45	0.45	0.45	0.45	0.45	0.45	0.45	0.45	0.45	-
A [mm]	9.54	8.97	8.97	9.2	8.97	9.2	8.97	9.2	8.97	9.2	8.8	10.5	-	-
Jn [mm]	0.240	0.215	0.215	0.219	0.215	0.219	0.215	0.219	0.215	0.219	0.263	0.176	-	-
ε	1.183	1.215	1.184	1.19	1.184	1.19	1.184	1.19	1.184	1.19	1.07	1.346	-	-
i	2.700	2.250	3.333	3.000	3.333	3.000	3.333	3.000	3.333	3.000	2.000	1.667	-	-
Co [Imp/L]			45.000		10.00		10.00		10.00		10.00			

A.D. INSA - INDUSTRIJA SATOVA

Tršćanska 21
11080 Beograd - Zemun
Republika Srbija

www.insa.rs



Fax:

E-mail:

+ 381 (11) 3713 - 600

+ 381 (11) 3713 - 607

+ 381 (11) 2614 - 330

office@insa.rs

info@insa.rs